

**ATMOZ 2-90**

**VACUUM PACKAGING MACHINE**



**FEATURES**

- Standard with 2 seal bars (front-back): 2 x 880 mm
- Standard double seal (two wires). Optional without extra costs: Cut-off or Wide seal (10 mm)
- Silicone holders easily removable for cleaning and maintenance purposes
- Pump capacity: 300 m<sup>3</sup>/h Busch vacuum pump
- Pump maintenance and cleaning program
- Machine cycle: 15-40 sec
- Standard Digital control with 10 program memory and Time control
- Flat work plate
- Comes with 1 layer of insert plates for a faster cycle and product adjustment
- Stainless steel exterior

**OPTIONS**

- 160 m<sup>3</sup>/h Busch vacuum pump
- 1-2 Cut-off seal
- Sensor control
- Liquid control
- ACS
- Gas flush (incl. pressed air connection)
- Soft Air to protect the product and vacuum bag

**ACCESSORIES**

- Inclined insert plate
- 2nd layer of insert plates
- Service kit for standard maintenance

**DESCRIPTION**

The robust, stainless steel Atmoz 2-90 vacuum packaging machine has a specific construction of both the lid and the work plate. This results in longer seal bars compared to other series. This double chamber floor model is standard equipped with a Busch vacuum pump and complies with CE standards.



Henkelman offers standard 1 year warranty on the Atmoz series.

**SEAL BAR CONFIGURATION**

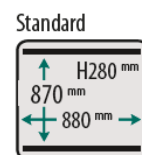

# VACUUM PACAGKING MACHINE ATMOZ 2-90 – SPECS

VACUUM PACKAGING MACHINE ATMOZ 2-90 – SPEC SHEET

## DIMENSIONS

In mm

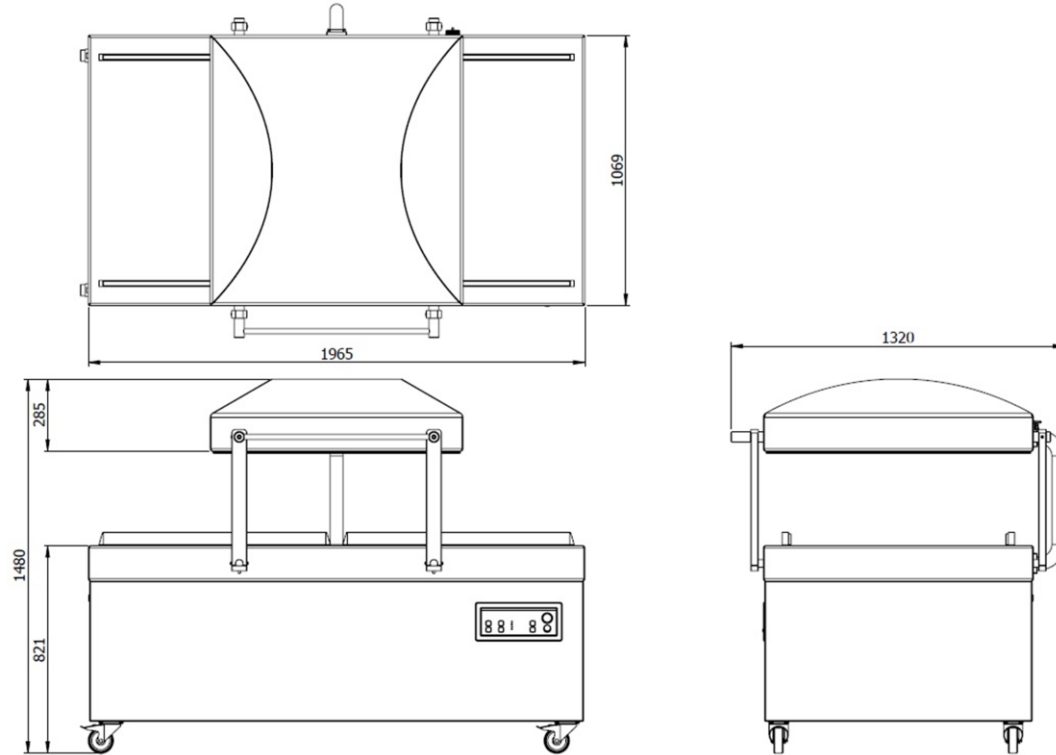

Model	Dimensions (mm)		Voltage* (Hz)	Pump capacity (m <sup>3</sup> /h)	Power (kW)	Weight (kg)
	Chamber (usable space) L x W x H	Machine L x W x H				
Atmoz 2-90	870 x 880 x 280	1320 x 1965 x 1106	400V-3-50	300	4,0 – 5,5	770

\* Other voltages available



HENKELMAN BV  
Titaniumlaan 10  
5221 CK 's-Hertogenbosch  
The Netherlands

**Sales support**  
P +31 73 621 36 71  
E [info@henkelman.com](mailto:info@henkelman.com)  
**Service/technical support**  
P +31 73 621 36 71  
E [service@henkelman.com](mailto:service@henkelman.com)